

Project Addendum No. 4

Project: **Pay Parking Improvements at the
Brownsville S.P.I. Int'l Airport
COB Bid No. PPI-30-0410** Addendum
Date: **April 8, 2010**

From: **Vicente Mendez, PE** Project No.: **3036**

Reference: Page(s): **Page 1 of 1**

Urgent For Review Please Comment Please Reply Please Recycle

This notice serves as Addendum No. 4 to the above referenced project. This addendum addresses items that have been clarified since Addendum no. 3.

CLARIFICATIONS

1. The Bid Due Date has been changed from Thursday April 8, 2010 at 2:00 PM. to Friday April 9, 2010 at 10:00 AM.
2. Update: A new updated bid schedule is included with this addendum. Previous schedules are to be ignored.
3. Clarification: Details Sheet- On the Typical Pavement Section – the note referring to **4” Caliche** at the bottom of the detail is to be ignored.
4. New Item: Handicap Signs – To be included in this item is the furnishing and installation of 8 standard parking lot handicap signs and assemblies. Detail is provided with this addendum.
5. New Item: Handicap Ramps – To be included in this line item is the cost to construct 3 concrete Handicap ramps per the detail supplied. The ramps shall match existing ramps. To be included in this item also is the cost of re-installing the detectable warning mats that were previously removed in the demolition of the existing ramps. Also to be included in this item is the cost to saw cut the existing asphalt surface, the preparation of the existing flexbase or subgrade, and the cost of any materials and labor. Ramps shall be ADA compliant.
6. Update: Pavement Markings – To be included in this line item will be the striping of 8 disabled, wheelchair, parking symbols on the respective stalls and offload area striping between stalls. An updated striping plan will be provided.
7. Update: Booth Improvements – To be included in this line item will be the cost of installing of the booth in the proposed location.

**BID SCHEDULE FOR THE
PAY PARKING IMPROVEMENTS
AT THE
BROWNSVILLE SOUTH PADRE ISLAND INTERNATIONAL AIRPORT**

ITEM	DESCRIPTION	EST. QTY.	UNIT	UNIT PRICE	COST
	Improvement Items				
1	1-1/2" HMAC (including leveling up of asphalt as necessary)	803	SY		
2	5" Crushed Limestone/7" Caliche Flexible Base	803	SY		
3	5% Type A Hydrated Lime. Mat'ls only.	11	TONS		
4	Demolition	1	LS		
5	Remove Exist. Conc. Curb &/or Curb & Gutter	350	LF		
6	Remove Concrete Walkway/Ramps	650	SY		
7	Prop Curb & Gutter	870	LF		
8	Prop Sidewalk Extension	17	SY		
9	Prop 5' Wide Valley Gutter(5ft wide / 6" thick)	5	SY		
10	Barrier Gate/ Ticket Dispenser Foundations	5	EA		
11	Storm Gutter (3' wide)	31	LF		
12	Electrical/Lighting(including conduit)	1	LS		
13	Communications(DSL,pt-to-pt & Telephone)	1	LS		
14	Concrete Bollards(installed)	43	EA		
15	Wheel Stops (installed)	118	EA		
16	Signs (installed)	1	LS		
17	Pavement Markings	1	LS		
18	Fencing (new and relocated)	1	LS		
19	Landscaping (sod only)	1	LS		
20	Booth Improvements	1	LS		
21	Booth Foundation	7	SY		
22	Irrigation (relocate/re-route existing as necessary;active)	1	LS		
23	Handicap Signs (provided and installed)	8	EA		
24	Handicap Ramps	3	EA		
	Total Bid Amount				\$ -
	Bid Amount(words)				

* Items in bold represent items that have changed, been updated, or clarified in this addendum - No. 4.

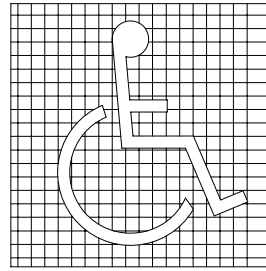

COLORS:

- LEGEND AND BORDER - GREEN
- WHITE SYMBOL ON BLUE BACKGROUND
- BACKGROUND - WHITE

HANDICAP SIGN

NOT TO SCALE

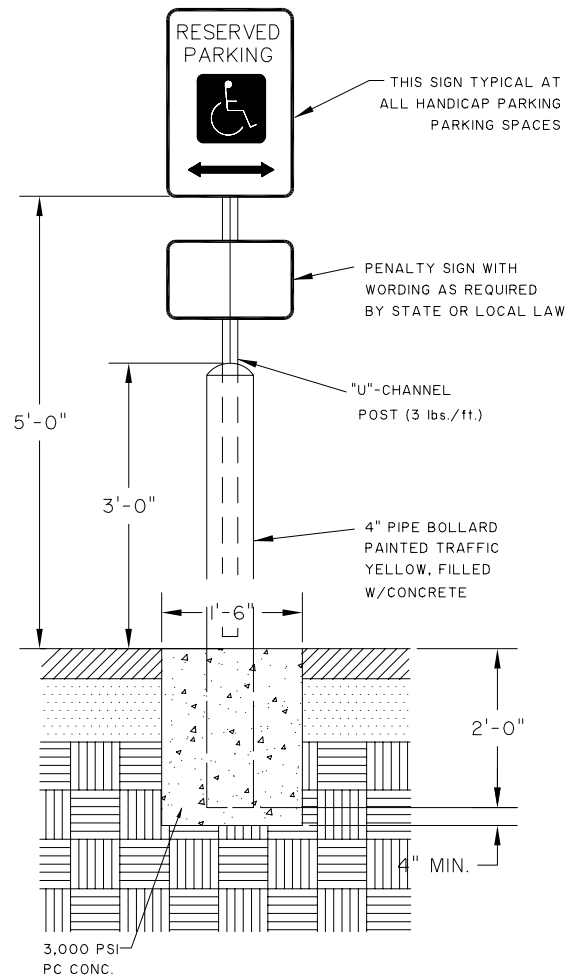

HANDICAP SIGN ASSEMBLY

NOT TO SCALE

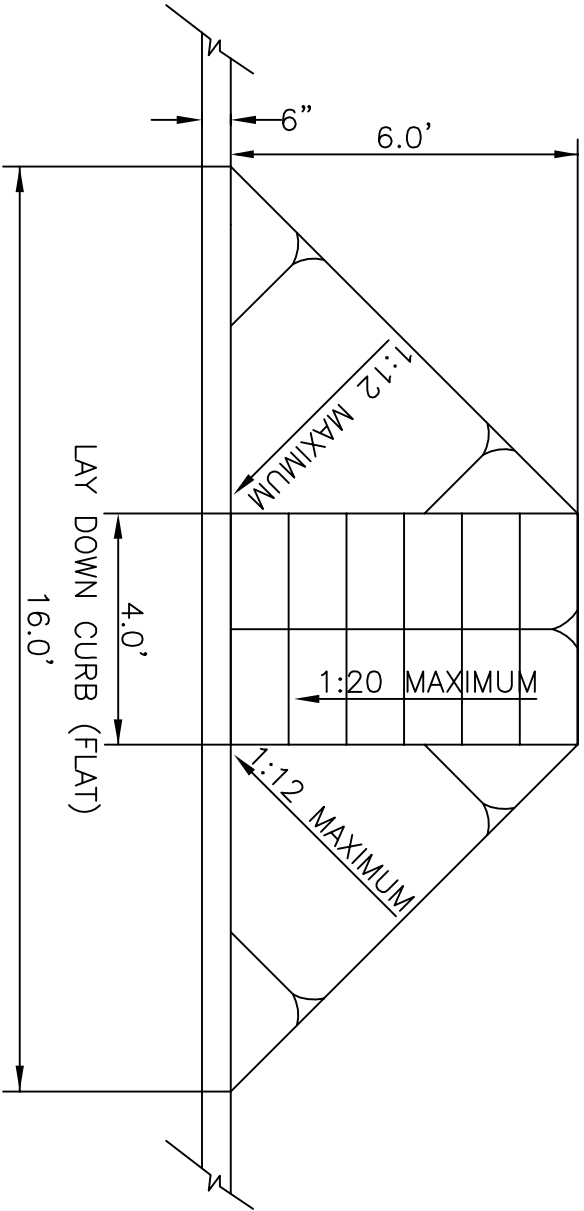

Handicap Ramp

N.T.S